



# MAGNITUDE

Sustainable Magnetic Wood Flooring





BESPOKE WOOD FLOORS

Est. 1999



Magnitude Sustainable Magnetic Wood Flooring powered by IOBAC combines our high quality Stability and Elegance FSC® engineered oak with a high strength magnetic film to provide a sustainable, circular, cost saving, adhesive free, contamination free and durable real wood floor installation.

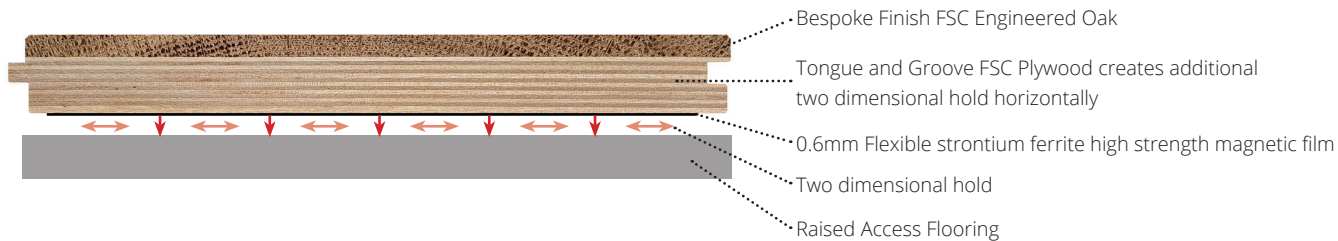

The combination of the tongue and groove planks and high strength magnetic film create a two dimensional hold vertically and horizontally to a magnetically receptive raised access floor.



We are certified to FSC® & PEFC standards.  This logo will identify the FSC-certified products throughout the brochure.

Please visit [www.wfa.uk.net](http://www.wfa.uk.net) or look through the price list for details of our FSC products.

## Bespoke Core Range & Formats

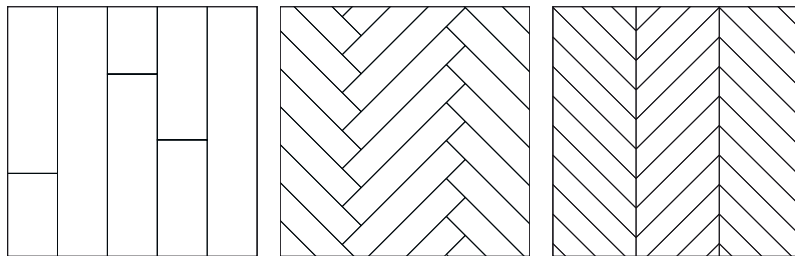

**PLANK**

**HERRINGBONE**

**CHEVRON**

The design possibilities are endless with 1000s of combinations of colours, textures, sizes and finishes available. Bespoke data sheets available on request.

\* To achieve our smoked and fumed finishes the timber is smoked. Although this is a controlled process there will be variation in colour tones as they are dictated by a reaction with the natural tannins within the Oak and sapwood will be made more apparent during this treatment. This process enhances the natural variation tones in the wood to create a beautiful varied appearance. Smoked floors will naturally lighten and mellow with time so please ensure you request a new sample for colour approval before placing an order.



## KEY BENEFITS

### **STRONG, YET REVERSIBLE HOLD**

- Powerful 2-dimensional hold.
- Tongue-and-groove mechanism locks planks together horizontally. A strong magnetic grip holds vertically to a magnetically receptive metal raised access floor.

### **SUSTAINABLE AND CIRCULAR – ADHESIVE FREE INSTALLATION**

- Maximises economic value and minimises environmental impact.
- Wood flooring is sustainable and finishes are plant and water based.
  - Easy to deconstruct, reuse, repurpose and recycle.
- Flooring can be reused, significantly reducing landfill waste and avoiding additional embedded carbon from new materials.
  - No sub-floor contamination – no messy, expensive remediation work.
    - The magnetic film is PVC, phthalate, plasticiser and VOC free.

### **IMPROVED HEALTH & WELLBEING**

- VOC's associated with wet adhesive installation methods are eliminated for improved Indoor Air Quality.
  - Magnetic backing does not interfere with hearing loops, Wi-Fi or electronic devices.

### **FAST INSTALLATION**

- Reduced labour time and cost – quick and clean to install and uplift.
- Minimal preparation required – no sealants, primers or plywood bases needed.
- The T&G planks require no additional pinning or fixing (providing installed to a level raised access floor).
  - Reduced maintenance costs.
  - Ease of access maintained.

### **DESIGN FLEXIBILITY**

- 20 core products or choose from our bespoke range with 1000s of combinations of colours, textures, sizes and finishes available.
  - Manufactured in the UK by WFA.



Magnitude Sustainable Wood Flooring contributes towards sustainability assessment certifications such as **BREEAM**, **SKA** and **LEED** by earning credits for material reuse.



#### **IMPROVED CIRCULARITY**

Flooring easily reused, avoiding additional embodied carbon.



#### **DESIGNED FOR DISASSEMBLY**

Maximises economic value and minimises environmental impacts through reuse, repair, remanufacture and recycling.



#### **ASSET PROTECTION**

Sub-floor undamaged, eliminating costly remedial or replacement work.

## WHERE CAN IT BE USED?

Commercial, Workspace, or any installation with a metal raised access floor.

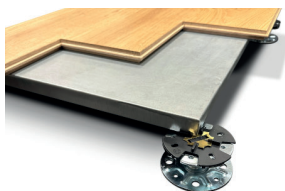

## SUBFLOOR REQUIREMENTS

The Subfloor **MUST** be to British Standard SR1 tolerance: maximum 3mm over a 2m straight edge.

Lipping between access panels must not be greater than 0.75mm.

The panels must be sound, dry, clean, free from contaminants and degreased if required prior to installing Magnitude Sustainable Magnetic Wood Flooring.

## REMOVAL AND REPLACEMENT OF PLANKS

Where designated access is required the boards can be adapted on site by removing the back of the groove.

There are two ways to remove the boards. Using a suction cup tool, or if the surface finish has a heavier texture the installation of flush ring pull handles is advised, please refer to our installation guidelines for full details.

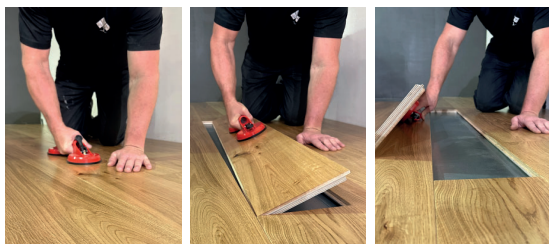

## Product Details - STABILITY

Product Description:	Stability 10 / 15 / 20mm
Wood Species:	European Oak
Construction:	Engineered
Product Type:	Plank / Herringbone / Chevron
Grade:	Select / Prime / Rustic
Profile:	Tongue & Grooved
Edge Profile:	1.50mm Micro Bevel - 2 Sided Plank and 4 Sided Herringbone & Chevron
Finish:	UV Oil - Extra Matt, Matt or Satin / BF
Size:	See Page 8 for details

Total Thickness:	<b>10mm</b>
Wear Layer:	3 / 4mm Oak Wear Layer
Core Layer:	7 / 6mm Multi Layer Birch Plywood
Total Thickness:	<b>11mm</b>
Wear Layer:	4mm Oak Wear Layer
Core Layer:	7mm Multi Layer Birch Plywood
Total Thickness:	<b>15mm</b>
Wear Layer:	4mm Oak Wear Layer
Core Layer:	11mm Multi Layer Birch Plywood
Total Thickness:	<b>20mm</b>
Wear Layer:	6mm Oak Wear Layer
Core Layer:	14mm Multi Layer Birch Plywood

## Technical Information

Country of Manufacture:	Europe
FSC®:	FSC 100% FSC-C111710
Lamination:	Hydraulic Cold Press
Glue Line:	D3 Water Based Glue
Norm:	EN 14342:2005+A1:2008
Reaction to Fire:	10 / 11 / 15mm - Dfl-s1 / 20mm - Cfl-s1
Density:	650 kg/m <sup>3</sup>
Formaldehyde Emissions:	Class E1 Zero Emissions
VOC Content:	Zero to low Emissions
Warmth Conduction W/m K (approx):	10mm 11mm 15mm 20mm 0.074 0.088 0.111 0.148
Production Tolerances;	
Width:	+/- 0.2mm
Thickness (Above T&G):	+/- 0.2mm
Length:	+/- 3.0mm Plank +/- 0.2mm Herringbone & Chevron
90° Angle:	+/- 0.3°

## Product Details - ELEGANCE

Product Description:	Elegance 15
Wood Species:	European Oak
Construction:	Engineered
Product Type:	Plank / Herringbone / Chevron
Grade:	Select / Rustic
Profile:	Tongue & Grooved
Edge Profile:	1.50mm Micro Bevel - 2 Sided Plank and 4 Sided Herringbone & Chevron
Finish:	UV Oil - Extra Matt, Matt or Satin / BF
Size:	See Page 10 for details
<b>Total Thickness:</b>	<b>15mm</b>
Wear Layer:	3 / 4mm Oak Wear Layer
Core Layer:	12 / 11mm Multi Layer Eucalyptus Plywood

## Technical Information

Country of Manufacture:	Europe
FSC®:	FSC 100% FSC-C111710
Lamination:	Hydraulic Hot Press
Glue Line:	Hot Melt Glue
Norm:	EN 14342:2013
Reaction to Fire:	15mm - Dfl-s1
Density:	780 kg/m <sup>3</sup>
Formaldehyde Emissions:	Class E1 Zero Emissions
VOC Content:	Zero to low Emissions
Warmth Conduction W/m K (approx):	15mm 0.13
Production Tolerances;	
Width:	+/- 0.2mm
Thickness (Above T&G):	+/- 0.2mm
Length:	+/- 3.0mm Plank +/- 0.2mm Herringbone & Chevron
90° Angle:	+/- 0.3°

## Magnetic Performance

Material Composition:	Magnetisation on one face only, 90% high grade ferrite powder, 10% synthetic binder FREE of PVC and phthalates
Magnetic strength:	42g per cm <sup>2</sup>
Hardness:	Shore-D - 33 ± 5
Thickness of Magnet:	0.6mm

## Grading

### SELECT

Maximum Size of Sound Knots:	Possible knots up to 10mm
Maximum Size of Filled Knots:	Possible knots up to 5mm
Filled Defects:	Allowed
Filler Type:	Coloured Filler to Complement the Wood
Sap Wood:	Minimal Edge Allowed
Colour Variation:	Natural Variation Allowed
Grain Variation:	Mixture of Natural Grain

### PRIME

Maximum Size of Sound Knots:	Possible knots up to 10mm
Maximum Size of Filled Knots:	Possible knots up to 5mm
Filled Defects:	Allowed
Filler Type:	Coloured Filler to Complement the Wood
Sap Wood:	Minimal Edge and Core Sap Wood
Colour Variation:	Natural Variation Allowed
Grain Variation:	Mixture of Natural Grain

### RUSTIC

Maximum Size of Sound Knots:	Up to 70mm
Maximum Size of Filled Knots:	Up to 35mm
Filled Defects:	Allowed
Filler Type:	Coloured Filler to Complement the Wood
Sap Wood:	Minimal Edge and Core Sap Wood
Cracks:	Allowed up to 150mm long
Colour Variation:	Natural Variation Allowed
Grain Variation:	Mixture of Natural Grain and Knots

### STABILITY

### ELEGANCE

## Installation

Installation Method: Magnitude Sustainable Magnetic Wood Flooring  
*Please also refer to our guidelines.* ✓

Site Conditions: 45 – 65% relative humidity & 15 – 25°C room temperature.

## Maintenance Advice

To fully aid in the care of the floor it is advised that all precautions are carried out. Avoid scratches by minimising grit and dust, install doorway entrance mats and apply felt pads to furniture. Use PH neutral cleaners and avoid soaking the floor with water at all times.

Recommended Products	Initial	Regular	Monthly	Long Term
Sweep / Vacuum:	✓	✓		
Osmo Wash and Care:		✓		
Osmo Maintenance Oil:				✓

**Guarantee:** 25 years; The lifetime of our guarantee covers the structural integrity of the product being the lamination, production, dimensions and grading. Please see our guarantee sheet for full details.



# STABILITY OAK

## DESIGNS & DIMENSIONS



### Plank

- 10/3 180 / 220mm (Random Lengths 600-2200mm)
- 10/4 140mm (Random Lengths 600-2200mm)
- 11/4 140 / 180 / 220mm (Random Lengths 600-2200mm)
- 15/4 140 / 180 / 220 / 240mm (Random Lengths 600-2200mm)
- 20/6 140 / 180 / 220 / 240 / 260 / 300mm (Random Lengths 1400-2400mm)

*Alternative dimensions are available upon request in all Stability design options.*

### Herringbone

- 10/4 70 x 490mm
- 10/4 15/4 20/6 90 x 500mm
- 15/4 20/6 120 x 600mm

### Chevron - 45 Degree Angle

- 10/4 15/4 20/6 90 x 500mm
- 15/4 20/6 120 x 600mm

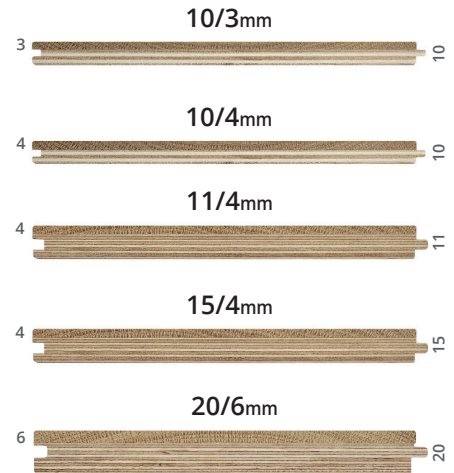



# STABILITY OAK

## GRADING



### PRIME

Clear grade with a mixture of natural grain.

#### KNOTS

Possible pin knots up to  $\leq 10\text{mm}$  and filled knots up to  $\leq 5\text{mm}$  diameter.

#### SAPWOOD

Minimal edge and core sapwood. ^

#### FILLED DEFECTS

Allowed.

#### FILLER TYPE

Coloured filler to complement the wood.

#### COLOUR

Natural variation allowed.

#### GRAIN

Mixture of natural grain.



### SELECT

Clean grade with a mixture of natural grain and minimal knots.

#### KNOTS

Sound knots up to  $\leq 30\text{mm}$  diameter and filled knots up to  $\leq 10\text{mm}$  diameter.

#### SAPWOOD

Minimal edge and core sapwood. ^

#### FILLED DEFECTS

Allowed.

#### FILLER TYPE

Coloured filler to complement the wood.

#### CRACKS

Possible up to  $30\text{mm}$  long.

#### COLOUR

Natural variation allowed.

#### GRAIN

Mixture of natural grain.



### RUSTIC

Has a good mixture of natural grain and plentiful knots.

#### KNOTS

Healthy sound knots up to  $\leq 70\text{mm}$  diameter with dead knots up to  $\leq 40\text{mm}$  and firmly filled holes up to  $35\text{mm}$  diameter.

#### SAPWOOD

Minimal edge and core sapwood. ^

#### FILLED DEFECTS

Allowed.

#### FILLER TYPE

Coloured filler to complement the wood.

#### CRACKS

Allowed up to  $150\text{mm}$  long.

#### COLOUR

Natural variation.

#### GRAIN

Mixture of natural grain and knots.

**GRADING RULES** Grading rules may vary from country to country and manufacturer to manufacturer. Please check at time of order for a certain product/range. ^ More apparent in smoked and fumed finishes.



# ELEGANCE OAK

## DESIGNS & DIMENSIONS



### Plank

- 15/3 190mm (*Lengths 1900mm*)
- 15/3 220mm (*Lengths 2200mm*)
- 15/4 260mm (*Lengths 2200mm*)

*Plank - up to 25% split boards  
per pack from 500mm*

### Herringbone

- 15/3 100 x 500mm
- 15/3 125 x 600mm

### Chevron - 45 Degree Angle

- 15/3 125 x 475mm





# ELEGANCE OAK

## GRADING

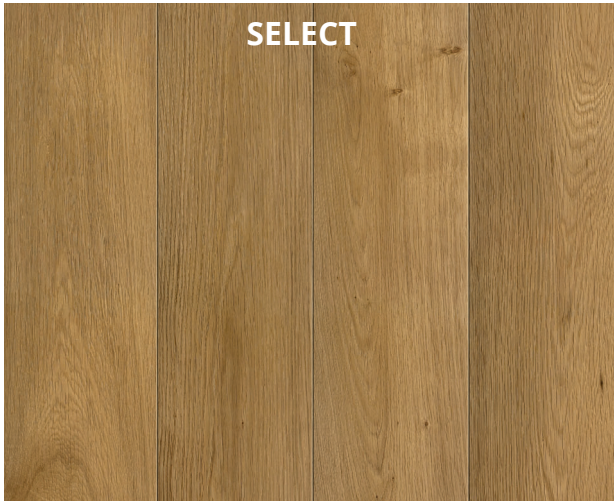

### SELECT

Clean grade with a mixture of natural grain and minimal knots.

#### **KNOTS**

Sound knots up to  $\leq 10\text{mm}$  and filled knots up to  $\leq 5\text{mm}$  diameter.

#### **SAPWOOD**

Minimal edge allowed. ^

#### **FILLED DEFECTS**

Allowed.

#### **FILLER TYPE**

Coloured filler to complement the wood.

#### **CRACKS**

Not allowed.

#### **COLOUR**

Natural variation.

#### **GRAIN**

Mixture of natural grain.



### RUSTIC

Has a good mixture of natural grain and plentiful knots.

#### **KNOTS**

Healthy sound knots up to  $\leq 40\text{mm}$  and firmly filled holes up to  $\leq 30\text{mm}$  diameter.

#### **SAPWOOD**

Allowed. ^

#### **FILLED DEFECTS**

Allowed.

#### **FILLER TYPE**

Coloured filler to complement the wood.

#### **CRACKS**

Allowed up to 150mm long.

#### **COLOUR**

Natural variation.

#### **GRAIN**

Mixture of natural grain and knots.

**GRADING RULES** Grading rules may vary from country to country and manufacturer to manufacturer. Please check at time of order for a certain product/range. ^ More apparent in smoked and fumed finishes.



BESPOKE WOOD FLOORS

*Est. 1999*

**Wood Floors & Accessories Limited** Spilsby Road • Harold Hill • Romford • RM3 8SB • United Kingdom

**T** +44 (0) 20 8501 6730 • **E** [info@wfa.uk.net](mailto:info@wfa.uk.net) • **W** [wfa.uk.net](http://wfa.uk.net)